

CASE
CONSTRUCTION

TR270

COMPACT TRACK LOADER



TR270 Compact Track Loader

LANDSCAPING'S LITTLE HEAVYWEIGHT.

Small in size and weight but big in power and performance, the TR270 is ideal for landscaping and applications requiring a light footprint. At less than 66 inches (1.68 m) wide and with an operating weight of only 8,270 lb. (3 750 kg), it won't disrupt ground conditions

and easily fits on most trailers. But don't let its compact size mislead you. Powered by a strong Tier 4 Final CEGR engine, this workhorse delivers best-in-class torque, breakout force and auxiliary hydraulic flow. It's a light loader that really packs a punch.



11

4

9

1

6

14

2

13

5

3

10

12

7

8

TR270 HIGHLIGHTS

- 1 New EZ-EH** setup menu provides a simple solution for speed and control customization, as well as, a new intuitive lockout option.
- 2 Enhanced control handles** for EH machines incorporate additional **industry-exclusive** feel points to aid the operator in feathering the controls.
- 3 Maintenance-free Tier 4 Final solution** delivers 10% more power over previous generations – with no additional fluids to add and no filters to replace.
- 4 Best-in-class torque, breakout force and standard and high aux flow** to tackle demanding applications.
- 5 One of the widest cabs in the industry** with a low threshold for easy entry and exit and an optional upgraded climate control system for year-round operator comfort.
- 6 Radial-lift design** for superior strength when digging, prying or pushing and perfect for easy loading or unloading of pallets.
- 7 Triple flange rollers** help prevent de-tracking on inclines by using dozer-style rollers with a larger inner diameter flange positioned between the track lugs.
- 8 Lifetime sealed and oil lubricated rollers and idlers** reduce the possibility of material and moisture getting into the rollers and idlers.
- 9 Standard side lighting, forward-cab design, a skylight and ultra-narrow wire side-screens** provide **best-in-class 360° visibility** day and night.
- 10 Large 19.5 gal (73.8 L) fuel tank** allows loader to run all day without refueling.
- 11 Hydraulic quick-coupler** enables operators to quickly and easily change attachments from the comfort of the cab.
- 12 All daily maintenance points** are easily accessible from the rear of the machine.
- 13 New electronic control module** feature logs operating data and has CAN-bus capabilities for diagnostic monitoring and telematics.
- 14 Fatigue-fighting options** include push-button Ride Control™, a self-leveling bucket feature, factory-fit foot controls and an advanced instrument cluster with programmable security codes and automatic shutdown.

Best-in-class torque, breakout and auxiliary flow.

The powerful new Tier 4 Final solution gives the added benefits of additional torque, auxiliary hydraulic flow, and bucket breakout force. The TR270 widens its lead in these categories for medium-frame CTLs with 232 lb.-ft. (314 N-m) of torque, 7,270 lb. (32.3 kN) of bucket breakout, a standard aux hydraulic flow of 24.2 gpm (91.5 L/min), and a high aux flow of 32.4 gpm (122.6 L/min). It's more strength to lift, move, and simply do more per day.

Maintenance-free Tier 4 Final Solution

The TR270 incorporates a unique Particulate Matter Catalyst* solution to meet Tier 4 Final emissions standards. What does that mean to you? We're proud to say – nothing. It's compliance that requires no extra work. No extra fluid to add. No filters to replace. Just get in and go. It's the best match for a machine of this size that often has multiple operators and is constantly on the go.

*PM Catalyst is made up of a DOC and a high efficiency flow-through filter

Love where you work.

At nearly three-feet wide, the TR270 offers one of the widest cabs in the industry. It's fully sealed and pressurized against noise, dust and fumes to keep out the bad and offers an optional radio and upgraded climate control system to keep in the good. Plus, a low threshold makes for easy entry and exit and its cab-forward design provides excellent site lines to bucket edges, curb lines and rearward.



TR270

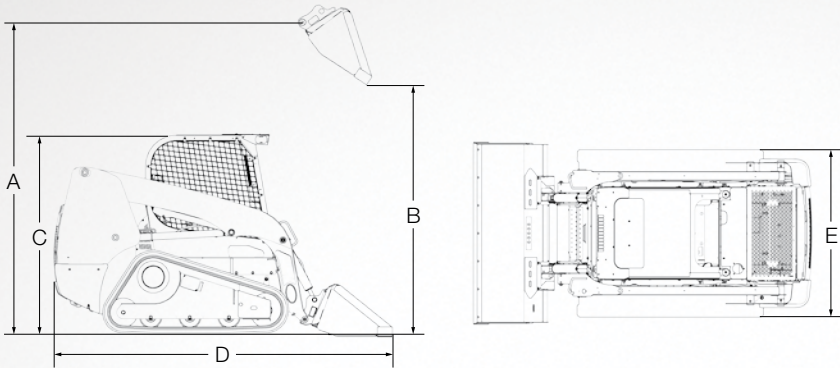

Line drawings are for illustrative purpose only and may not be exact representation of unit.

DIMENSIONS

	TR270
A. Height To Bucket Hinge Pin	123.0 in. (3.12 m)
B. Dump Height With Foundry/ Excavating Bucket	98.2 in. (2.50 m) @ 40°
C. Height To Top Of ROPS	78.7 in. (2.00 m)
D. Overall Length With Foundry/ Excavating Bucket	129.6 in. (3.29 m)
E. Over The Track Width	65.9 in. (1.68 m)

SPECIFICATIONS	TR270
Engine Make/Model	FPT F5H FL463 A
Emissions Certification*	Tier 4 Final (Particulate Matter Catalyst)
Gross hp (kW) @ 2500 RPM	74 (55)
Net hp (kW) @ 2500 RPM	68 (51)
Peak Torque – lb.-ft. (N-m) @ 1400 RPM	232 (314)
Displacement/Cylinders – in. ³ (L)	207 (3.4)/4
Rated Operating Capacity – ROC 35% – lb. (kg)	1,890 (860)
Rated Operating Capacity – ROC 50% – lb. (kg)	2,700 (1 225)
Tipping Load – lb. (kg)	5,400 (2 449)
Bucket Cylinder Breakout Force – lb. (kN)	7,270 (32.3)
Auxiliary Hyd. Standard/High Flow – gpm (L/min)	24.2 (91.5) / 32.4 (122.6)
Operating Weight – lb. (kg)	8,270 (3 750)
Lift Configuration	Radial

NOTE: *PM Catalyst is composed of DOC and a high efficiency flow-through filter; DOC = Diesel Oxidation Catalyst.

Maintenance Made Easy.

When you buy a CASE, you want it to last. We make it easy. That's why on Alpha Series compact track loaders, routine service points are all located at the rear of the machine so you can quickly access the engine, filters, fill points and whatever you need to properly maintain and extend the life of the machine. On top of that, they also offer our famous easy-tilt cab for convenient access to the drivetrain compartment.



Adaptable Power.

Standard auxiliary hydraulic flow has been increased to 24.2 gpm (91.5 L/min) and optional high-flow to 32.4 gpm (122.6 L/min) to power your high-performance attachments, making both standard and high-flow best-in-class. And with our Connect Under Pressure (CUP) manifolds, you won't need any tools to connect or disconnect hydraulic lines.



© 2014 CNH Industrial America LLC. CASE is a trademark registered in the United States and many other countries, owned by or licensed to CNH Industrial N.V., its subsidiaries or affiliates. CNH Industrial Capital is a trademark in the United States and many other countries, owned by or licensed to CNH Industrial N.V., its subsidiaries or affiliates. Printed in U.S.A.

Form No. CCE201406TR270



SAFETY™ NEVER HURTS

Always read the operator's manual before operating any equipment. Inspect equipment before using it, and be sure it is operating properly. Follow the product safety signs and use any safety features provided.

All engines meet current EPA emissions regulations.

All specifications are stated in accordance with SAE standards or recommended practices, where applicable.



Contains 10% post-consumer fiber

IMPORTANT: CASE Construction Equipment Inc. reserves the right to change these specifications without notice and without incurring any obligation relating to such change. Availability of some models and equipment builds vary according to the country in which the equipment is used. The illustrations and text may include optional equipment and accessories and may not include all standard equipment. Your CASE dealer/distributor will be able to give you details of the products and their specifications available in your area.



CASE construction equipment is biodiesel-friendly.